

Himax Contractor High Bay



Himax combines energy savings and low cost, with high performance and design ingenuity, to satisfy most light industrial applications. The fixture optics are highly efficient with 74% LOR and comes complete with lamp

and flex and plug.

Applications

- Warehouses
- Loading Docks
- Work Shops
- Factory Units
- Exhibition Halls
- Production Areas

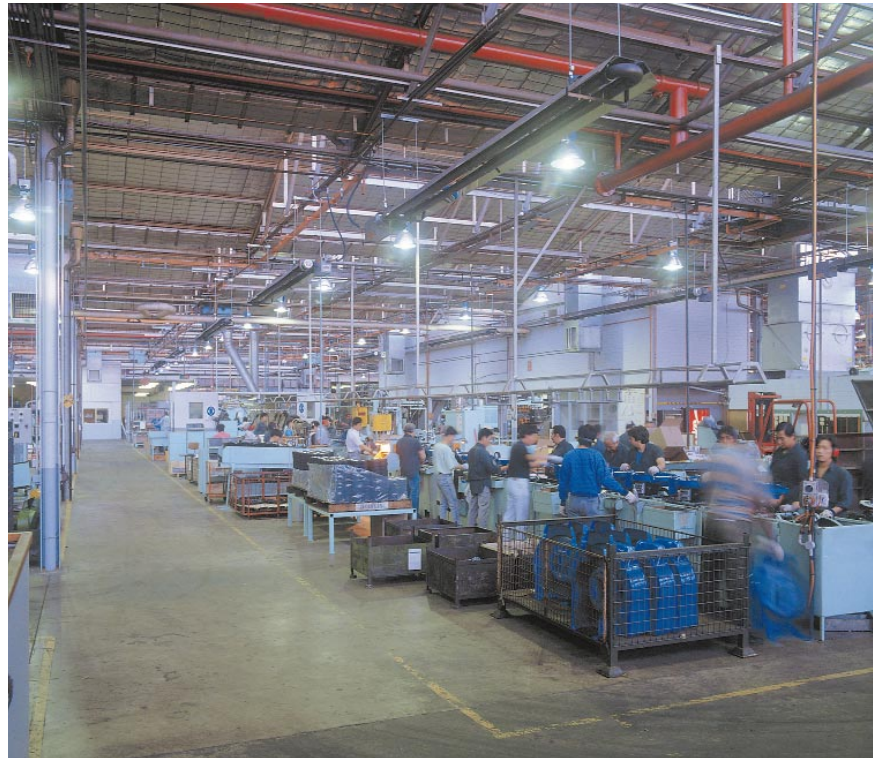

Photometric design data

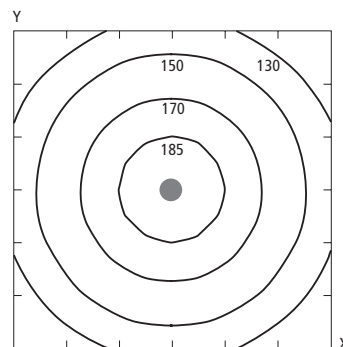

Horizontal illumination – Himax BHMx400MBF

Ceiling height – 6.0m Area – 6m x 6m
 X increments = 1.0m Y increments = 1.0m
 Plane height = 0.85m
 No allowance made for wall and ceiling reflectances

Wired to AS3137 and EMC approved

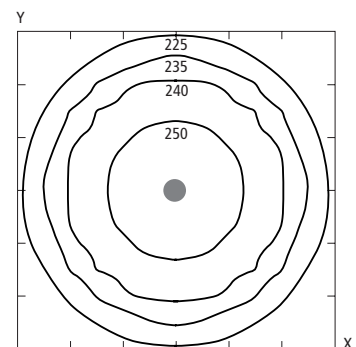

Horizontal illumination – Himax HMX400MHI

Ceiling height – 6.0m Area – 6m x 6m
 X increments = 1.0m Y increments = 1.0m
 Plane height = 0.85m

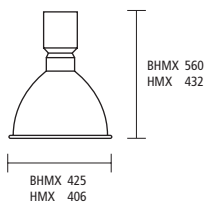

Product reference

Supplied complete with control gear and lamp

BHMx250MBF	HQL250W	HPF
BHMx400MBF	HQL400W	HPF
HMX250MHI	MI250/U	HPF
HMX400MHI	MI400/U	HPF

HMX250SON	NAVE250	HPF
HMX400SON	NAVE400	HPF

Accessories

HMXWG	wire guard
-------	------------