

CMF ceiling centrifugal ducted fans

- Bathrooms
- Hotels
- Restaurants and Pubs
- Offices



Features

- Pressure developing, high performance centrifugal extractor fan.
- Stylish design, in white finish to blend with modern decor.
- FD Flexible ducting must be used with the fan and where condensation is present, an XCT trap must be used.
- Easy to install with the steel mounting frame included with the fan.
- Clip off front cover for easy cleaning and maintenance.
- Low operating noise level.
- Maximum ambient temperature application is 50°C.
- Motor lubricated for life and fitted with a thermal cut-out.
- Complies with EMC requirements and Australian Standard AS/NZS 3350.
- 1 year warranty.

Accessories

- FD100/4-5 – 100mm x 4.5m thermal flexible ducting suits CMF241.
- FD150/6 – 150mm x 6m thermal flexible ducting suits CMF271.
- WDC125/5PK – 100-125mm worm drive clips suits flexible ducting.
- WDC200/5PK – 150-200mm worm drive clips suits flexible ducting.
- CFWG100 – wall or eave exterior grille, suit 100mm ducting.
- CFWG150 – wall or eave exterior grille, suit 150mm ducting.
- DT20 – time delay switch controller.
- XRH – humidity sensor unit.
- XPIR – remote passive infrared sensor unit.
- AQS – air quality sensor unit.
- XCT100 – condensation trap suits CMF241.

For more details see accessories page 8.

Dimensions

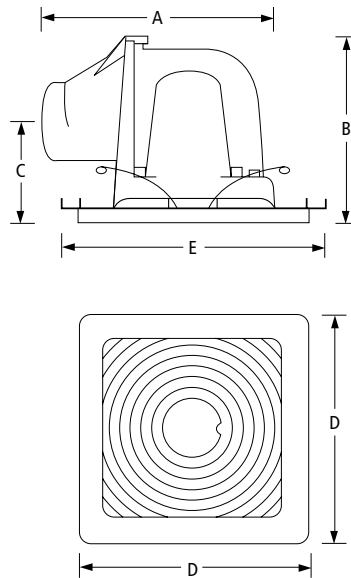

	CMF241	CMF271
A	343	420
B	260	318
C	133	133
D	290	320
E	319 ²	350 ²
Ducting dia.	102	150
Aperture	248 x 248	273 x 273
Weight (kg)	3.8	6.9

All dimensions in mm.

Installation

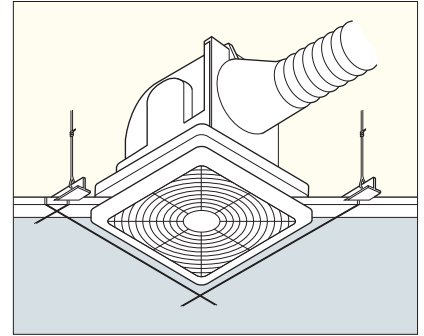

Simple installation features a metal clamping frame which acts as a template and strengthens the installation into the ceiling. The fan is a cassette type unit which allows the ducting to be installed prior to the fan itself.

Specifications

Product Reference	Sound Pressure (dbA) at 3m	Extract Performance (FID) at 240V-50Hz Litres/Second Fan Only	Extract Performance (FID) at 240V-50Hz m ³ /Hour Fan Only	Power Usage (Watts)	Installation Options	Switching Operation (Switch not included)
CMF High Performance Centrifugal Extractor Fans						
CMF241	39.5	41	146	32	Ceiling/Ducted	Remote
CMF271	33.5	78	282	50	Ceiling/Ducted	Remote

Please refer to Xpelair Fan Selection Guide on page 9. For full details on the accessory range see page 8.